



Office of the Councillors  
**BELDANGA MUNICIPALITY**  
P.O. BELDANGA, PIN-742133, DT. MURSHIDABAD  
ESTD-1981

From :- Chairperson

Phone :- +91 8100479708

E-Mail ID :- [beldanga.municipality@gmail.com](mailto:beldanga.municipality@gmail.com) &  
[chairmanbeldanga2010@gmail.com](mailto:chairmanbeldanga2010@gmail.com)

Website :- [www.beldangamunicipality.org](http://www.beldangamunicipality.org)

Memo No. .... 888/11-1/23

Date..... 28/03/23

**Quotation Notice**

Quotation are invited on behalf of Board of Councillors, Beldanga Municipality from Reputed Contractors for Construction Maintenance of Road & Drain from Rakhi Sweets Shop under ward no. 8 in Beldanga Municipality, Murshidabad.

**The Terms and Conditions are as under**

1. All Quotation shall have to reach to the office of the under signed within the specified time and date. The drop box is placed at the office chamber of the under signed.
2. Security Deposit money @2% will be deducted during bill payment & will be returned after 1 year, If No maintenance works needed to this work during 1 year of completion.
3. The intending quotationer should apply for quotation papers in respective Letter Heads enclosing self-attested Photocopies' of valid Trade License, PAN, valid P-TAX Challan, etc. as applicable.
4. Recoveries towards Govt. Taxes. Cess. GST will be deducted from the bill of the contractor on the basis of prevailing Govt. Rules.
5. Quotation will be accepted as per rules. However the undersigned reserves the right to accept or reject any or all quotation without assigning any reason what so ever.
6. Loading, Unloading and Carrying cost are to be borne by the Contractor.
7. Estimated Amount :- Rs 30,224.00
8. Last Date of submitting quotation :- 10.04.2023 (1 pm.)
9. Date of opening the quotation :- 10.04.2023 (2 pm.)
10. Date of Issuing Work Order :- 10.04.2023 (3 pm)
11. Date of Work to be completed within :- 10.05.2023 (within 4 pm.)

The rate and Total Amount for the above noted work are as Follows:-

Sl. No	Name Work	Rate including All Taxes.
1	Maintenance of Road & Drain from Rakhi Sweets Shop under ward no. 8 in Beldanga Municipality, Murshidabad.	

*[Signature]*  
Chairperson

Beldanga Municipality

Date..... 28/03/23

Memo No- 888(8)/11-1/23

**For wide Publicity and information, copy forwarded to**

1. The Vice Chairman, Beldanga Municipality.
2. The Executive Officer Beldanga Municipality.
3. The Finance Officer, Beldanga Municipality.
4. The Representative Engineer, MED, Murshidabad.
5. All S.A.E, Beldanga Municipality,
6. Accountant, Beldanga Municipality,
7. Notice Board, Beldanga Municipality.
8. IT Coordinator, Beldanga Municipality to upload the notice of Beldanga Municipal Website, ([www.municipalitybeldanga.org](http://www.municipalitybeldanga.org))

*[Signature]*  
Chairperson

Beldanga Municipality

**Beldanga Municipality**  
**Murshidabad**

**Estimate for  
Maintenance of Road & Drain from Rakhi Sweets Shop under ward no.8 in Beldanga Municipality, Murshidabad.**

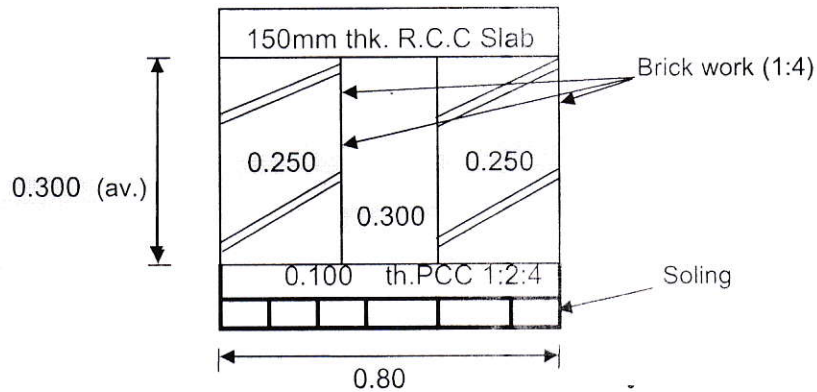

**Cross section of Drain**  
Not to Scale

Drain Length = 4.50 Meter

Road & Bridge Works PWD (WB)

Page- 331 , Item- 18.02

- 1 Picking up and removing old bituminous layer or sand sealing coat from old black topped surface and cleaning the exposed surface by scraping and stacking the material as directed.

(a) By manual means :

iii) Above 100 mm thick.

$$\text{Drain } 1 \times 4.50 \times 0.80$$

$$= \frac{3.60 \text{ Sqm}}{3.60 \text{ Sqm}} @ \text{ Rs. } 45.20 / \text{ Sqm Rs. } 162.72$$

Building Works PWD (WB)

Page- 1 , Item- 2

- 2 Earth work in excavation of foundation trenches or drains, in all sorts of soil (including mixed soil but excluding laterite or sandstone) including removing, spreading or stacking the spoils within a lead of 75 m. as directed. The item includes necessary trimming the sides of trenches, levelling, dressing and ramming the bottom, bailing out water as required complete.

(a) Depth of excavation not exceeding 1,500 mm.

$$\text{Drain } 1 \times 4.50 \times 0.80 \times 0.500 \text{ (av.)}$$

$$= \frac{1.80 \text{ Cum}}{1.80 \text{ Cum}} @ \text{ Rs. } 119.27 / \text{ Cum Rs. } 214.69$$

Building Works PWD (WB)

Page- 14 , Item- 1 , 3rd Corrigenda

- 3 Single Brick Flat Soling of picked jhama bricks including ramming and dressing bed to proper level and filling joints with local sand.

$$\text{Drain } 1 \times 4.50 \times 0.80$$

$$= \frac{3.60 \text{ Sqm}}{3.60 \text{ Sqm}} @ \text{ Rs. } 326.00 / \text{ Sqm Rs. } 1173.60$$

- 4 Providing & laying cement concrete(1 : 2 : 4) with graded stone chips. (20mm nominal size)

$$\text{Drain } 1 \times 4.50 \times 0.80 \times 0.100 = 0.36 \text{ Cum}$$

$$2 \times 4.50 \times 0.800 \times 0.150 = 1.08 \text{ Cum}$$

---

$$1.44 \text{ Cum} @ \text{Rs. } 5359.18 / \text{Cum} \text{ Rs. } 7717.22$$

Building Works PWD (WB)

Page- 15 , Item- 7 , 3rd Corrigenda

- 5 Brick work with 1st class bricks in cement mortar (1:4) (a) In foundation and plinth

$$\text{Drain } 2 \times 4.50 \times 0.250 \times 0.300 = 0.68 \text{ Cum}$$

---

$$0.68 \text{ Sqm} @ \text{Rs. } 4928.00 / \text{Sqm} \text{ Rs. } 3351.04$$

Building Works PWD (WB)

Page- 42 , Item- 36

- 6 Hire and labour charges for shuttering with centering and necessary staging upto 4 m using approved stout props and thick hard wood planks of approved thickness with required bracing for concrete slabs, beams and columns, lintels curved or straight including fitting, fixing and striking out after completion of works (upto roof of ground floor)

(f) 25 mm to 30 mm shuttering without staging in foundation

Drain	2 x 4.50 x 0.100	=	0.90 Sqm		
Slab	8 x 2 x 1.00 x 0.150	=	0.30 Sqm		
	8 x 2 x 0.80 x 0.150	=	0.24 Sqm		
			<hr/>		
			1.44 Sqm	@ Rs. 205.00 / Sqm	Rs. 295.20

Building Works PWD (WB)

Page- 43 , Item- 40 , 9th Corrigenda

- 7 Reinforcement for reinforced concrete work in all sorts of structures including distribution bars, stirrups, binders etc initial straightening and removal of loose rust (if necessary), cutting to requisite length, hooking and bending to correct shape, placing in proper position and binding with 16 gauge black annealed wire at every intersection, complete as per drawing and direction.

(i) Tor steel/Mild Steel

II. JSW/JSPL/SHYAM/

10 mm Dia

$$8 \times 9 \times 0.65 = 46.80 \text{ Meter}$$

$$8 \times 5 \times 1.15 = 46.00 \text{ Meter}$$

---

92.80 Meter

$$@ 0.617 \text{ Kg/m} = 57.26 \text{ Kg}$$

$$= 57.26 \text{ Kg}$$

$$= 0.057 \text{ Mt} @ \text{Rs. } 55394.00 / \text{Mt} \text{ Rs. } 3157.46$$

Building Works PWD (WB)

- 8 Ordinary Cement concrete (mix 1:1.5:3) with graded stone chips (20 mm nominal size) excluding shuttering and reinforcement if any, in ground floor as per relevant IS codes.

(i) Pakur Variety

$$8 \times 1.00 \times 0.800 \times 0.150 = 0.96 \text{ Cum}$$

---

$$0.96 \text{ Cum} @ \text{Rs. } 5853.02 / \text{Cum} \text{ Rs. } 5618.90$$

Building Works PWD (WB)

Page- 189 , Item- 1 , 3rd Corrigenda

9 Plaster (to wall, floor, ceiling etc.) with sand and cement mortar including rounding off or chamfering corners as directed and raking out joints including throating, nosing and drip course, scaffolding/staging where necessary (Ground floor).[Excluding cost of chipping over concrete surface]

(i) With 1:6 cement mortar  
 (b) 15 mm thick plaster

1 x 4.50 x 0.900 = 17.23 Sqm  
 17.23 Sqm @ Rs. 139.53 / Sqm Rs. 2404.10

10 Neat cement punning about 1.5mm thick in wall, dado, window sill, floor etc.. NOTE:Cement 0.152 cu.m per100 sq.m.

Same as area of plaster at sl.no. 9 = 17.23 Sqm  
 17.23 Sqm @ Rs. 34.00 / Sqm Rs. 585.82

4433.11  
 290.62  
 871.85  
 twenty four  
 32.75  
 564.28  
 24,628.41  
 Add G.S.T. @ 18% = Rs. 4442.54  
 29,061.52  
 Labour Welfare Cess @ 1% = Rs. 291.23  
 29,352.14  
 Contingency @ 3% = Rs. 873.70  
 30,223.99  
 Say = Rs. 30288.22  
 30,224.00

Rupees Thirty Thousand Two Hundred EightyEight Only

*[Signature]*  
 S.A.E.  
 Beldanga Municipality

*[Signature]*  
 (Anuradha Hazra Banerjee)  
 Chairperson  
 Beldanga Municipality

*[Signature]*  
 20.12.22  
 JUNIOR ENGINEER  
 Murshidabad Division, M.E.Dte  
 Dept. of Urban Dev. & Municipal Affairs  
 Govt. of West Bengal

MAY BE VETTED  
 Assistant Engineer  
 Murshidabad Division  
 M.E. Directorate  
 Dept. of U.D.M.A.  
 Govt. of West Bengal

VETTED  
*[Signature]*  
 21/12/22  
 EXECUTIVE ENGINEER  
 MURSHIDABAD DIVISION M.E. DTE